

Biosolids as a Resource: Towards a Paradigm Shift in the 21st Century

Rob Smith, P.E., BCEE
Project Engineer
Malcolm Pirnie, Inc.

Sam Jeyanayagam, PhD, P.E., BCEE
Senior Associate
Malcolm Pirnie, Inc.

**OWEA Biosolids Systems Workshop
December 10, 2009**

**MALCOLM
PIRNIE**

Solutions for Life™

The Current Paradigm

Wastewater and wastewater sludge are wastes.

The New Paradigm

“Sustainability is driving the industry to take on the new challenge of transforming wastewater treatment from an energy-consuming and waste-producing activity to one with positive net energy production and minimal residuals.”

*- Rogalla, F., Tarallo, S., Scanlan, P. and Wallis-Lage, C.,
Sustainable Solutions, WE&T April 2008*

References

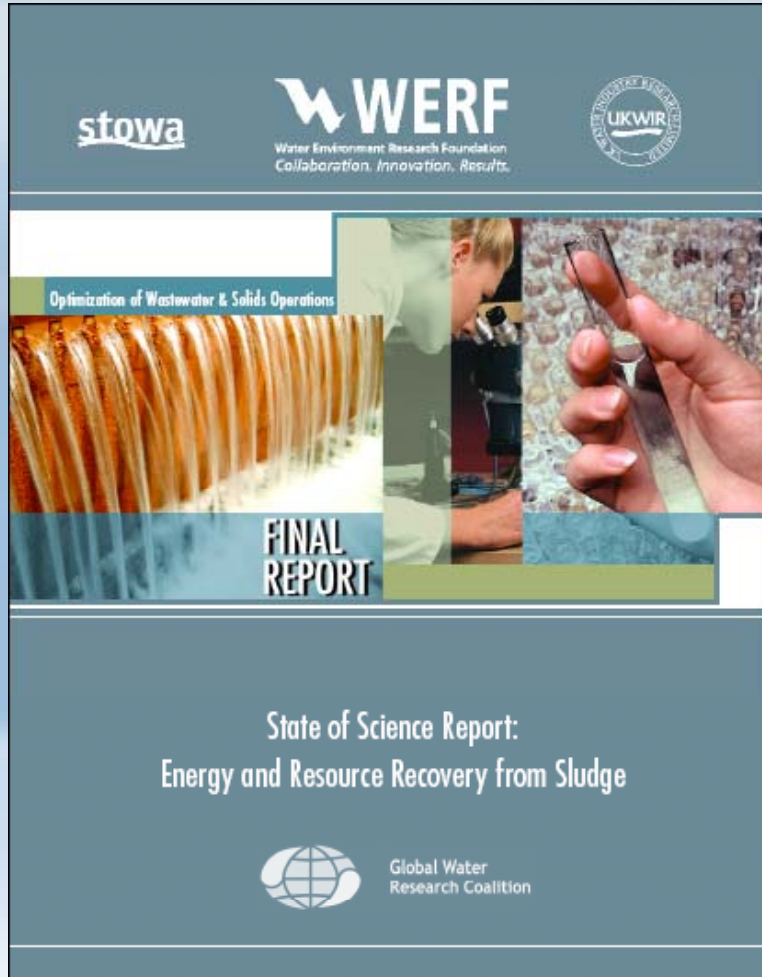

Available for free to WERF subscribers:

www.WERF.org

References

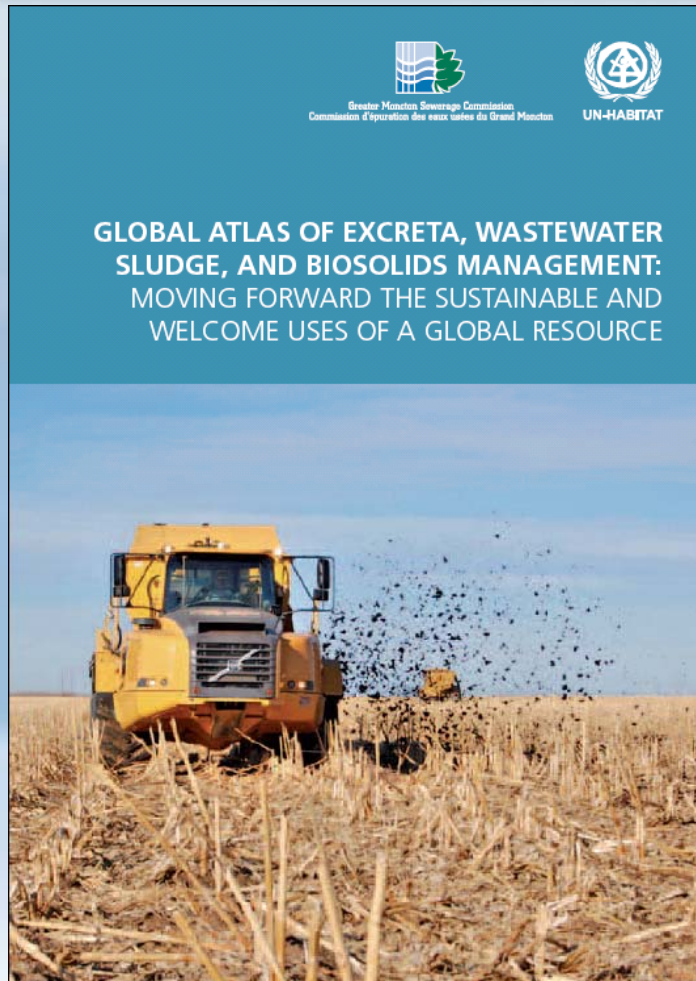

The Atlas is available for free download at:

www.unhabitat.org/pmss/getPage.asp?page=bookView&book=2551

Printed copies including the CD version may be ordered from the same website.

References

Phosphorus A Looming Crisis

**By: David A. Vaccari
Scientific American
June 2009**

References

Kroiss H. (2004): What is the potential of utilizing the resources in sludge?
Wat.Sci.Tech. 49 (10), pp 1-10

Shizas, J.I. and Bagley D. (2004). Experimental determination of energy content of unknown organics in municipal wastewater streams. Journal of Energy Engineering, ASCE, 130(2), 45-53.

Mignone, N., (2008), Fad or Future? An expert evaluates whether digester-gas-fed fuel cells and microturbines are cost-effective sources of power, Water Environment & Technology, v.20 n.10, ppg. 42-47

McDaniel, M, Wheless, E, The power of digester gas, Water Environment & Technology, v.20 n.6, ppg. 37-41

Tweed, K., Sewage's cash crop, Scientific American, November 2009.

Outline

- **Keywords and Concepts**
- **Market Drivers**
- **The Status and Future of Biosolids Production, Reuse, and Disposal**
- **The Importance of Phosphorus**
- **Phosphorus Recovery Technologies**
- **Energy Importance, Independence and Environmental Impact**
- **Energy Recovery from Wastewater Sludge**
- **Feasibility**

Outline

- **Keywords and Concepts**
- Market Drivers
- The Status and Future of Biosolids Production, Reuse, and Disposal
- The Importance of Phosphorus
- Phosphorus Recovery Technologies
- Energy Importance, Independence and Environmental Impact
- Energy Recovery
- Feasibility

Keywords and Concepts

- **A growing population and intensified human activity increases energy demand and depletes resources.**
- **As resources and cheap energy deplete technologies will emerge to recover resources and energy from wastewater.**
- **Wastewater is a source for resources and energy.**

Keywords and Concepts

- **Resource**
- **Beneficial Use**
- **Sustainability**
- **Struvite**
- **Greenhouse Gas (GHG)**
- **Energy Recovery System (ERS)**
- **Established Technology**
- **Cogeneration**
- **Microturbine**
- **Fuel Cell**
- **Pyrolysis**

Outline

- Keywords and Concepts
- **Market Drivers**
- The Status and Future of Biosolids Production, Reuse, and Disposal
- The Importance of Phosphorus
- Phosphorus Recovery Technologies
- Energy Importance, Independence and Environmental Impact
- Energy Recovery
- Feasibility

Market Drivers

- Sustainability/ Environmental Concerns
 - Soil Pollution
 - GHG
 - Resource depletion
- Energy Cost and Type
- Resource Quality and Quantity
- Regulation / Legislation

World Population Growth

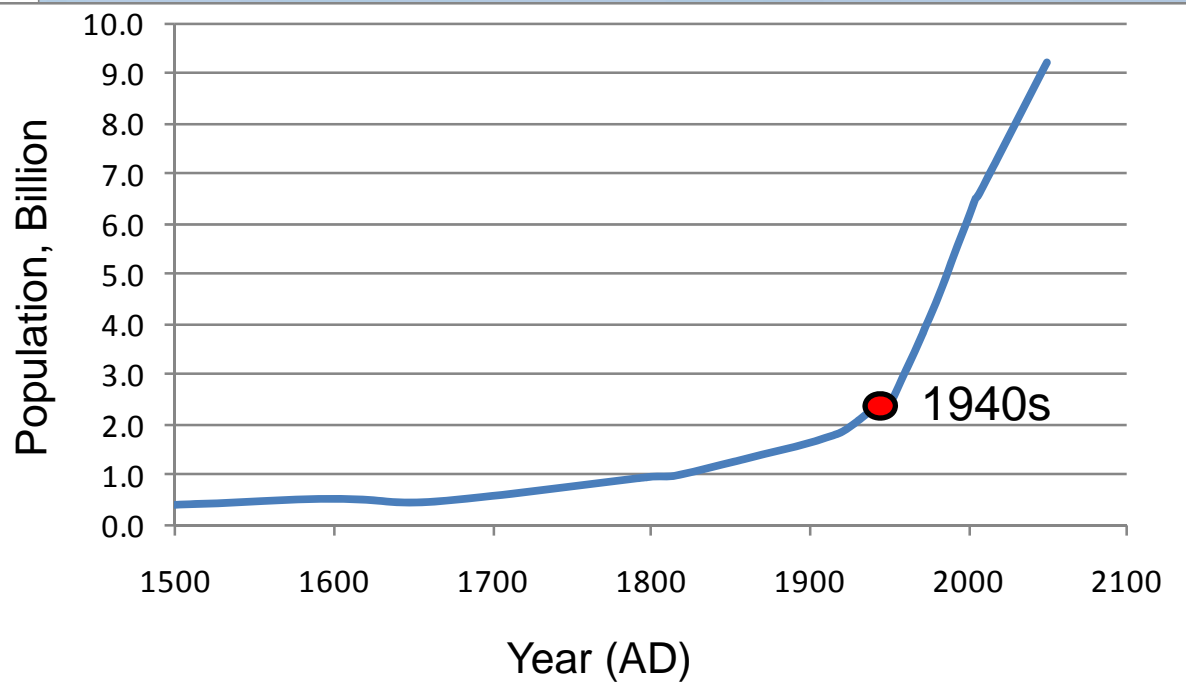
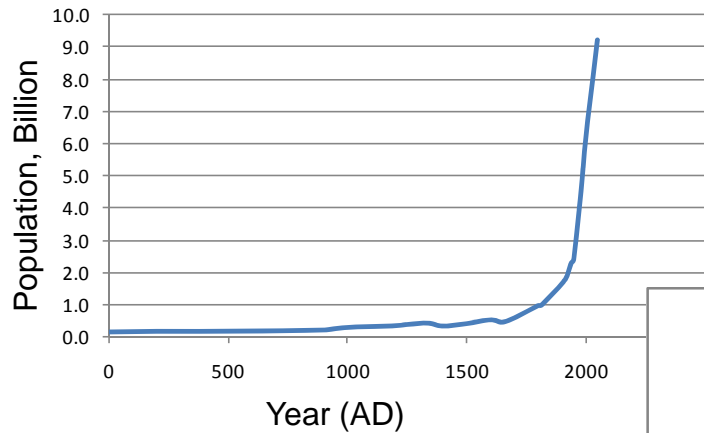

Development of World Cities

1950

**World Cities exceeding
5 million residents**

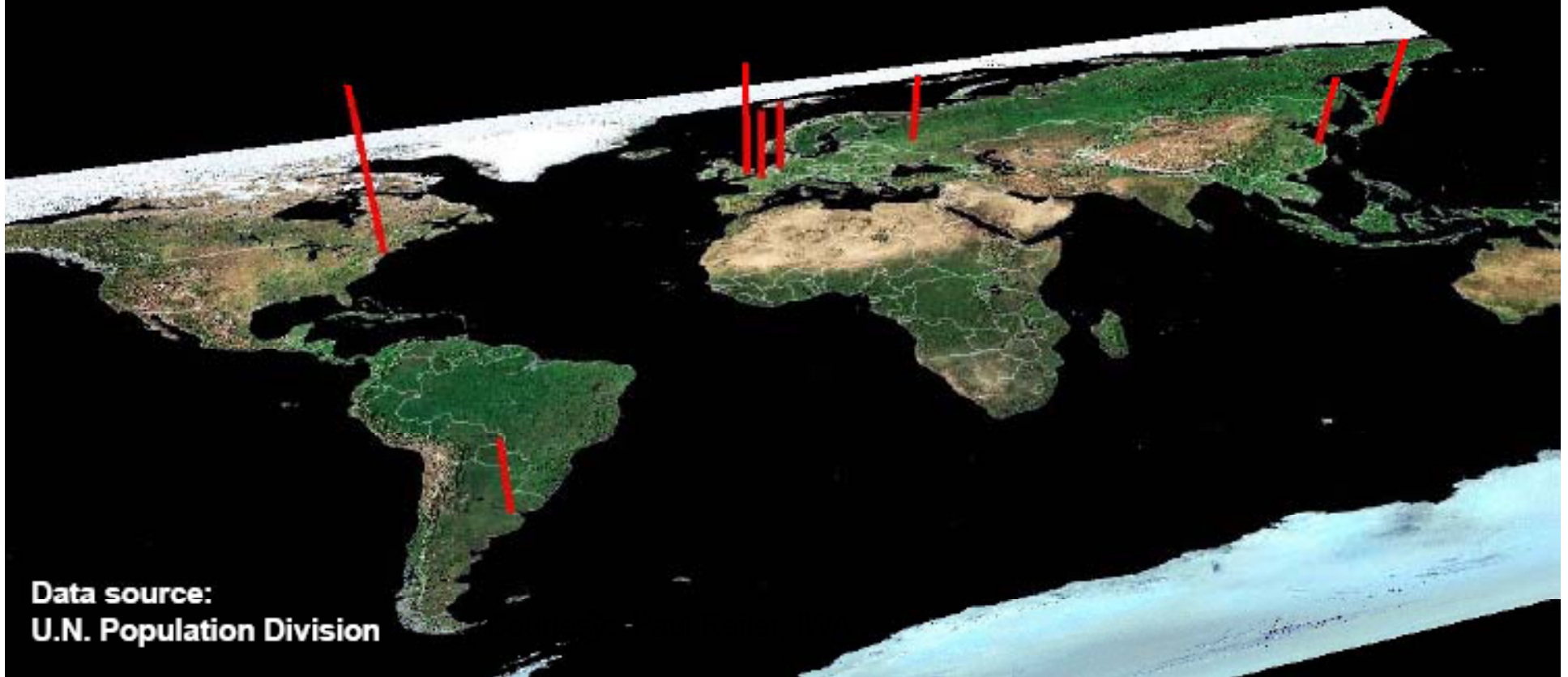

Development of World Cities

2000

**World Cities exceeding
5 million residents**

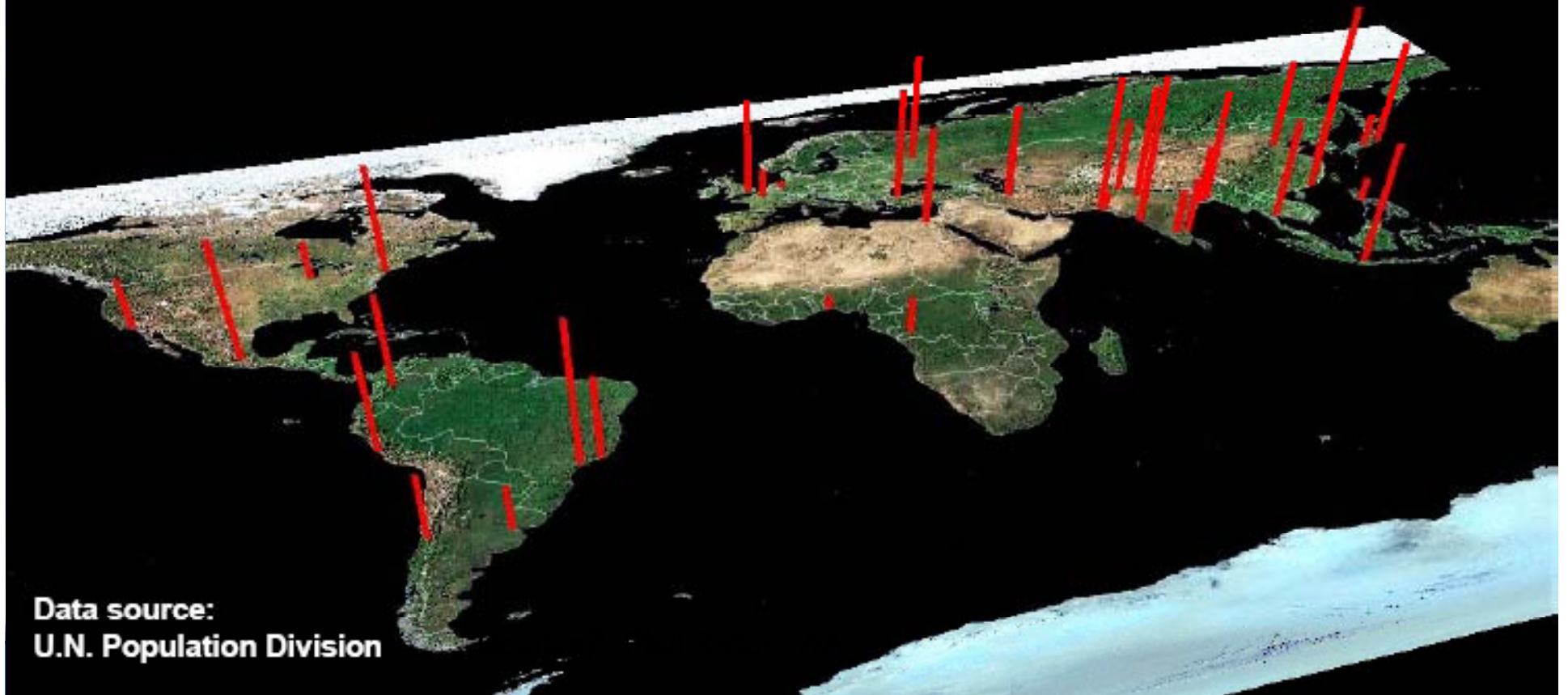

Development of World Cities

2015

**World Cities exceeding
5 million residents**



Data source:
U.N. Population Division

Sewage Sludge Production - EU

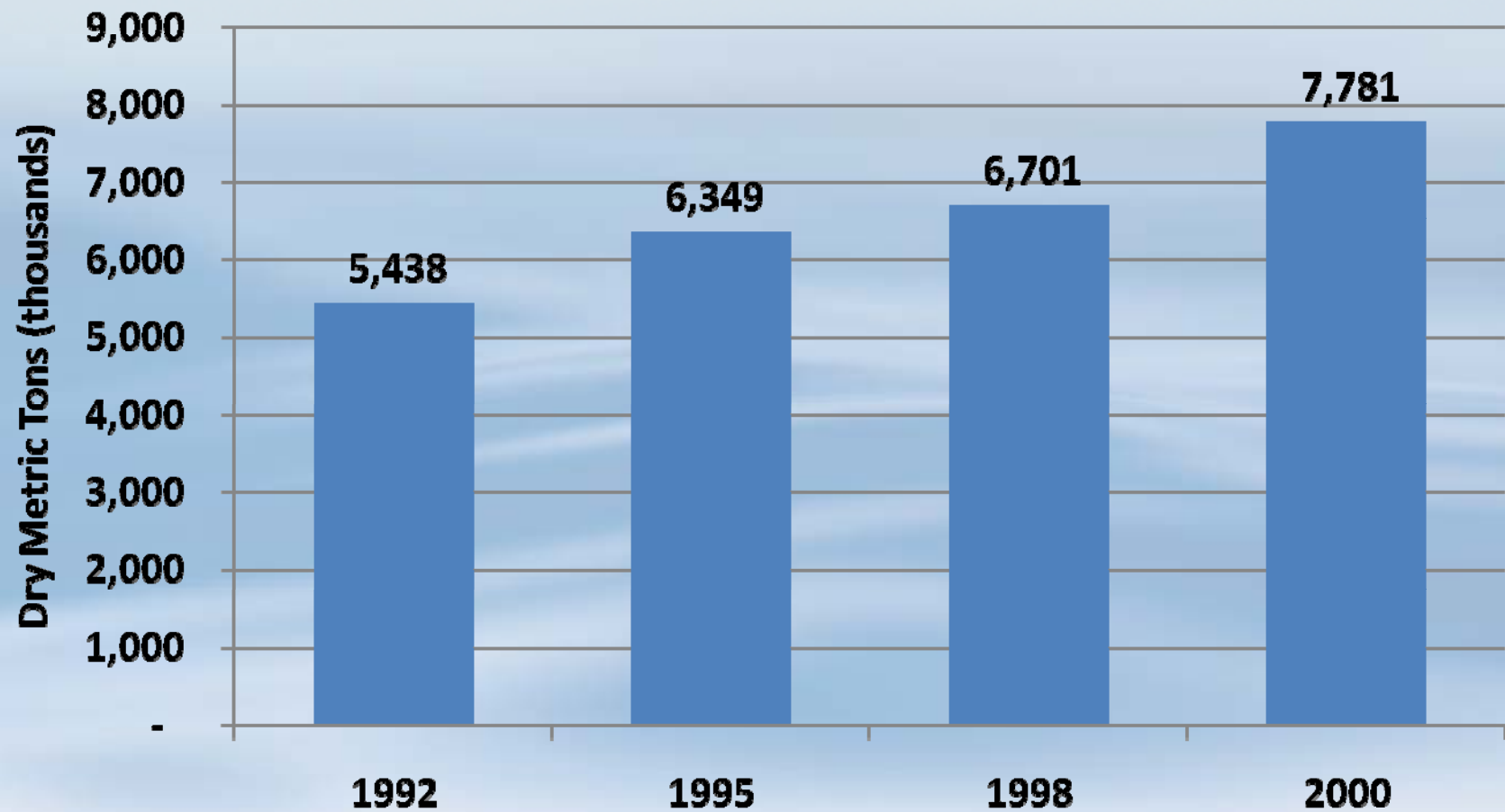

The Current Status of Biosolids Disposal/Reuse in the U.S.

- **Agricultural use (49%)**
 - Sewage contains useful nutrients for crops
 - Low cost
- **Land Disposal (30%)**
- **Incineration (15%)**
- **Other (6%)**

Ohio Sludge Disposal

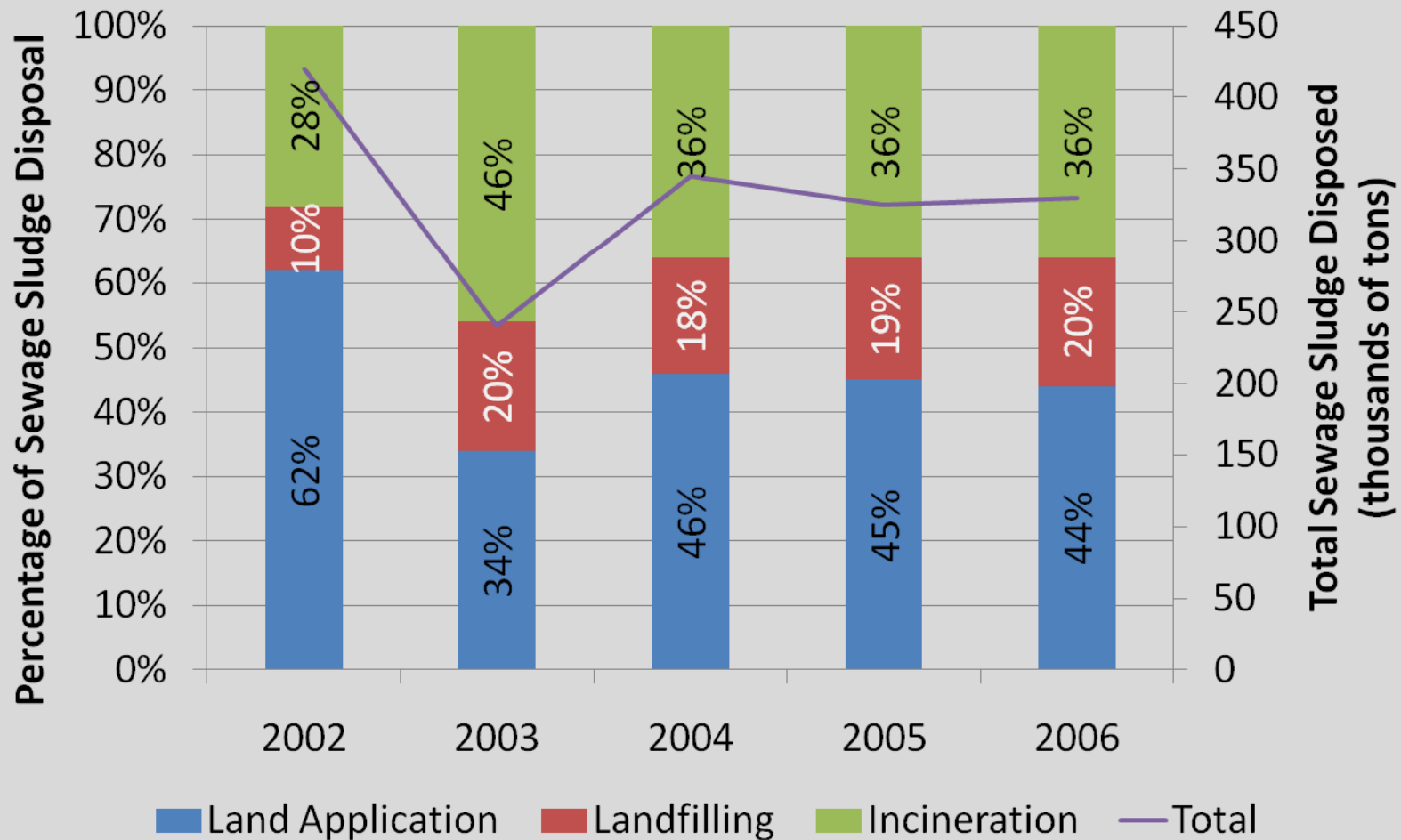

Source: Ohio EPA Division of Surface Water

The Future of Agricultural Reuse

- **0.3% of available agricultural land in U.S. is required for land application of estimated future biosolids production.**
- **In many locations land application is no longer well accepted by the public, farming organizations, and the food industry**
- **Local opposition sometimes forces cities to transport biosolids a great distance even when amply suitable farmland is nearby.**

Products Recoverable from Sewage Sludge and their Final Use

Type of Product	Use of Product
Methane	Electricity, heat, fuel
Gases	Electricity, heat
Oil, fat, grease	Biodiesel, methane
Phosphorus	Fertilizers
Nitrogen	Fertilizers
Metals	Coagulants
Inorganic material	Building material
Organic compounds	Organic acid production
Inoculum	Bio-hydrogen gas production
Crystal proteins, spores	Bio-pesticides production

Treatment Processes for Resource Recovery

Resource Recovered / Process Type	Example of Technology
Phosphorus	
Chemical Processes	KREPO, Seaborne, Aqua-Reci, Kemicond, BioCon, SEPHOS
Crystallization Processes	Crystalactor[®], PhoStrip[®], Ostara
Building Material	
Thermal Solidification	GlassPack[®]
Incineration	Portland Cement
Nitrogen	
Chemico-process	ARP Technology
Volatile Acids	
Microbiological	Fermentation
Hydrothermal	Wet air oxidation

“Phosphorus is the most valuable compound in sewage sludge”

- **Sustainability**
- **Economic value**
 - **Finite reserves**
 - **Nitrogen in atmosphere is unlimited and can be recycled through photosynthesis**

Outline

- Keywords and Concepts
- Market Drivers
- The Status and Future of Biosolids Production, Reuse, and Disposal
- **The Importance of Phosphorus**
- Phosphorus Recovery Technologies
- Energy Importance, Independence and Environmental Impact
- Energy Recovery
- Feasibility

The Importance of Phosphorus

- **Phosphorus is an irreplaceable ingredient of life.**
- **An average human body contains 650 g of Phosphorus.**
- **The average adult consumes and excretes 1 to 3 grams/day of Phosphorus.**

Phosphorus Independence

- **Mining phosphorus for fertilizer is consuming the mineral faster than geologic cycles can replenish it.**
- **U.S. reserves will last 40 years at current production.**
- **Phosphorus in WW is 10% of mined phosphate rock.**

Phosphorus Independence

- **Sweden has mandated that 60% of phosphate be recycled from wastewater**
- **In 2008, China slapped a 135% export tariff on phosphate.**

Phosphorus Reserves Worldwide



Together with nitrogen and potassium, phosphorus is a crucial ingredient in fertilizer. It is extracted from phosphorus-rich rock in the form of phosphate. Morocco, China, South Africa and the U.S. hold 83 percent of the world's easily exploitable phosphate rock and contribute two thirds of the annual phosphorus production (circles, below). At current rates of extraction (bars, below), known U.S. reserves are projected to last 40 years. Globally about 90 years' worth of phosphorus remains. Once the resource starts running out, less economical supplies may have to be tapped, which could result in higher prices and market disruptions. Already production has been declining despite the incentive of increasing prices (graph, right); last year the price spiked up because of tight supply and increased demand.

U.S. PRODUCTION IN DECLINE AS PRICE SOARS
Phosphate Rock Production (millions of metric tons)

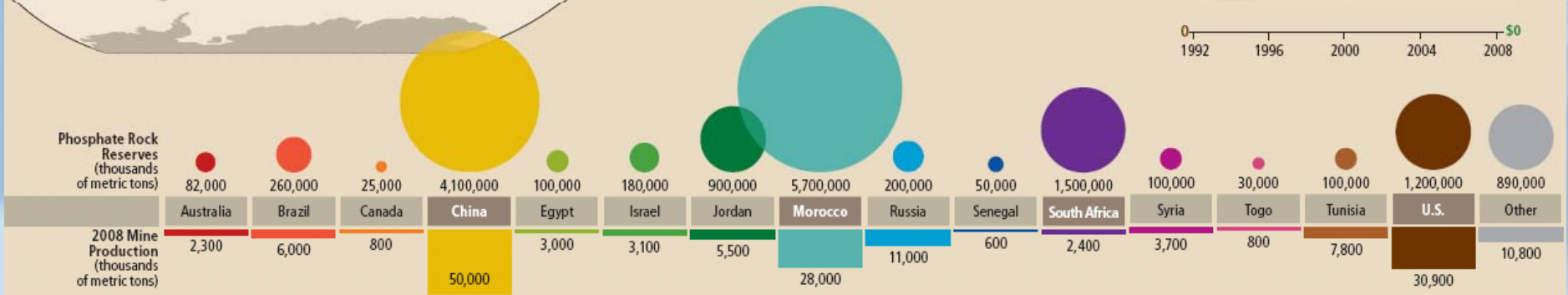

Phosphorus Environmental Impact

- **Most WWTPs are not designed to remove Phosphorus – passes through, “lost”, to receiving stream.**
- **Some Phosphorus is recycled when land application is practiced.**
- **80% of mined phosphate rock used in food production is leached from farm fields**
- **Excess phosphorus in waterways helps to feed algal blooms, which starve fish of oxygen, creating “dead zones”.**

Outline

- Keywords and Concepts
- Market Drivers
- The Status and Future of Biosolids Production, Reuse, and Disposal
- The Importance of Phosphorus
- **Phosphorus Recovery Technologies**
- Energy Importance, Independence and Environmental Impact
- Energy Recovery
- Feasibility

Phosphorus Recovery Technologies

P Recovery Process	Feed Stream	Product	External Inputs
Crystalactor	RAS	CaPO ₄	chemicals
PhoStrip	RAS	CaPO ₄	chemicals
Ostara	Digester supernatant	struvite	chemicals
KREPO	Primary Sludge	Ferric Phosphate	heat, pressure, chemicals
Kemicond	Primary Sludge	Ferric Phosphate	chemicals
Seaborne	Digested sludge	struvite	heat, chemicals
BioCon	Incinerator ash	H ₃ PO ₄	chemicals
SEPHOS	Incinerator ash	CaPO ₄	chemicals

PhoStrip[©]

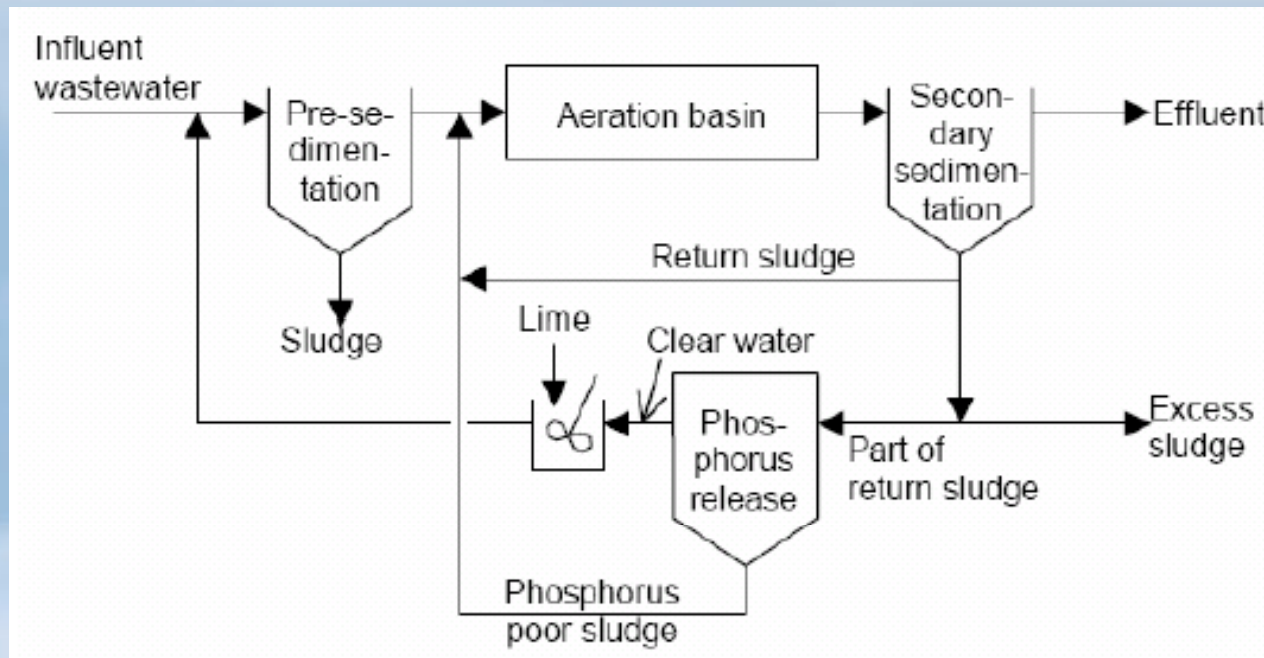

Cystalactor[®]

- **Fluidized Bed Reactor**
- **Crystallization of a variety of metal carbonates, phosphates, halides, sulfates and sulfides.**
- **Developed in the Netherlands by DHV**
- **Originally for water softening.**
- **Broad application across many industries.**

Crystalactor diagram

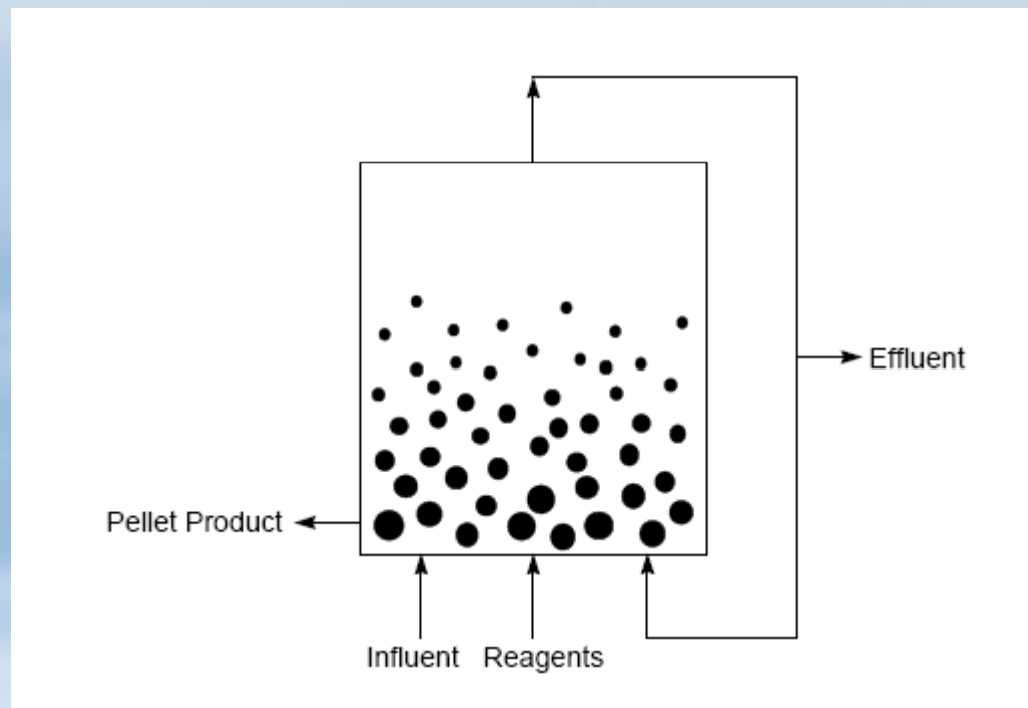

Crystalactor[®] Case Study

- **Food Processor**
- **200,000 gpd**
- **80 – 100 mg/L P in WW**
- **Traditional coagulation also evaluated**
- **\$1.6 million**
 - **Includes reactor, equalization, chemical systems, pumps**
- **Relationship with POTW a factor**
 - **No sludge to haul to POTW, CaPO₄ pellets “disposal” essentially free**

Ostara Struvite Recovery System

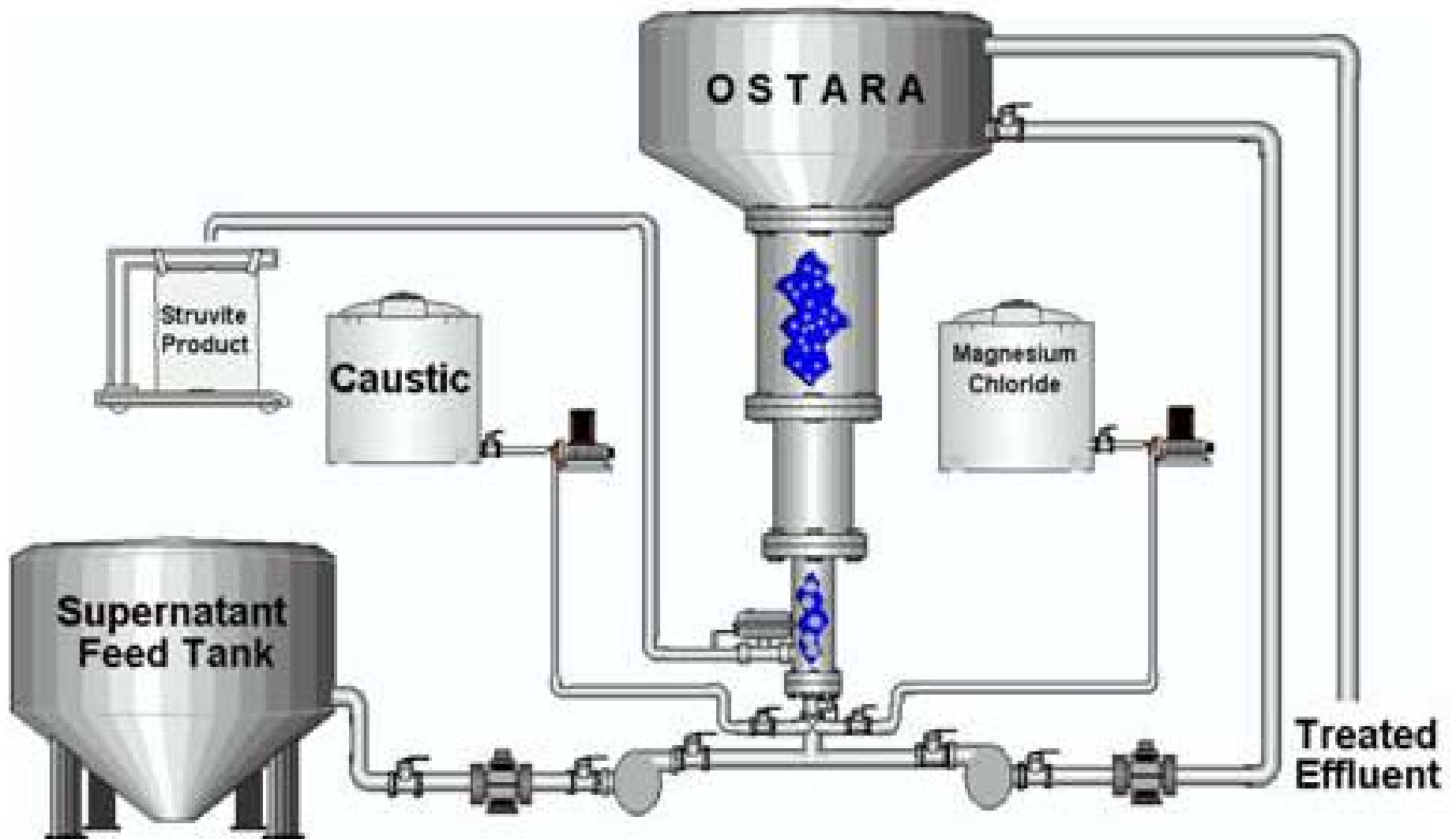



Crystal Green



Ostara Installations

- **Edmonton, Alberta Gold Bar WWTP (82 MGD)**
 - May 2007
 - 200 – 250 MT struvite / year
 - \$2.5 million Cdn
- **Clean Water Services' Durham WWTF (20 MGD)**
 - June 2009
- **HRSD Nansemond (30 MGD)**
 - 2010
- **York, PA WWTP (26 MGD)**
 - 2010

Building Material Recovery

- **ALWA, Brick, Slag, Ceramic, Cement, Glass, interlocking tile.**
- **Except for brick and cement production, materials are produced after incineration.**

Glasspack[®]

- **Glasspack[®] is a patented vitrification (melting) process developed by Minergy Corporation.**
- **North Shore Sanitation District (NSSD), Zion, IL has used the process since September 2006 to produce glass aggregate which is used in utility trenches.**

Outline

- Keywords and Concepts
- Market Drivers
- The Status and Future of Biosolids Production, Reuse, and Disposal
- The Importance of Phosphorus
- Phosphorus Recovery Technologies
- **Energy Importance, Independence and Environmental Impact**
- Energy Recovery
- Feasibility

The Importance of Energy

- **A plentiful source of clean, inexpensive energy is essential to quality of life.**

The Future of Energy

- **The price of energy is anticipated to rise**
- **WWTPs are net consumers of energy**
- **Energy is a large component of operating costs**
- **The cost of WWTP operation is anticipated to rise with energy costs**
- **As regulations become more stringent, energy consumption must increase**

Energy Environmental Impact

- **DW and WWTPs account for 3% of U.S. electric load.**
- **WWTPs account for 0.7% (50 Tg CO₂) of U.S. GHG emissions.**
 - **16 Tg of CO₂**
 - **1.2 Tg of CH₄ (25.4 Tg CO₂ equivalents)**
 - **25.8 gigagrams of nitrous oxide (8.0 Tg CO₂ equivalents)**

Energy Potential

**Energy in Sewage : Energy Required
to Treat Sewage**

10 : 1

Outline

- Keywords and Concepts
- Market Drivers
- The Status and Future of Biosolids Production, Reuse, and Disposal
- The Importance of Phosphorus
- Phosphorus Recovery Technologies
- Energy Importance, Independence and Environmental Impact
- **Energy Recovery**
- Feasibility

Treatment Processes for Energy Recovery

Process Type	Example of Technology
Sludge-to-Biogas	
Anaerobic Digestion	mesophilic, thermophilic, two-phase, tpad
Pre-Treatment Thermal Hydrolysis	Cambi [®] , Biothelsys [®]
Pre-Treatment Physical-chemical cell destruction	Microsludge [™] , ultrasonic, ozonation, pulse electric
Sludge-to-Syngas	
Gasification	KOPF, EBARA
Incineration	Thermylis [®] , HTFB
Sludge-to-Oil	
Pyrolysis	Enersludge [™] , SlurryCarb [™]
Hydrothermal	STORS
Sludge-to-Liquid	
SCWO	Aqua-Reci [®] , Aqua CitroX [®] , Athos [®]

Energy Recovery from Anaerobic Digestion

- **Anaerobic digestion produces methane (biogas).**
- **Biogas energy recovery systems (ERS) can be used to produce heat and power.**
- **Biogas-derived heat and power can help WWTPs meet or exceed their own heat and energy needs.**
- **< 20% of WWTPs convert their biogas into heat or energy**

Microturbines

- **Small, single-stage combustion units**
- **Advantages:**
 - Low NO_x emissions
 - High energy recovery efficiency (w/ exhaust heat recovery)
 - Simple operation that is easily contracted out
- **Disadvantages:**
 - Gas pretreatment

Microturbine Diagram

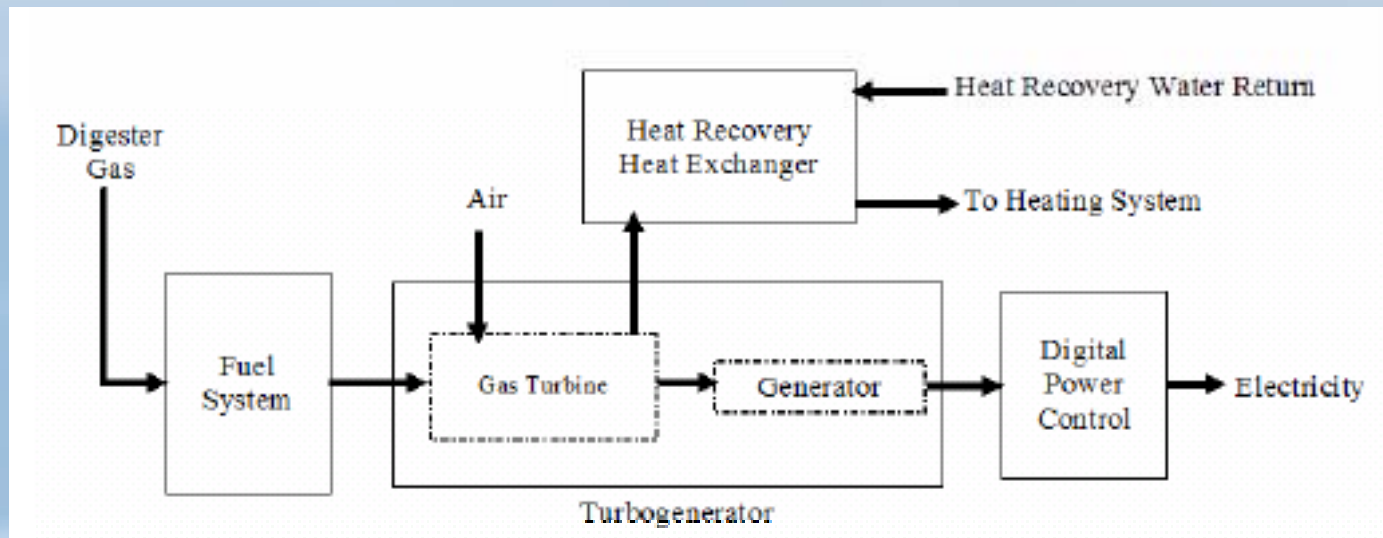

Microturbine Components

- **Fuel system**
- **Gas generator**
- **Turbine**
- **Power control**
- **Heat recovery / heat exchanger**

Microturbines Full Scale

- **Lewiston , NY (2001)**
 - 2 x 30 kW units
 - \$225k
- **Lancaster, CA (2004)**
 - 1 x 250 kW unit

250 kW Microturbine



Fuel Cells

- **Produce electrical power directly through an electrochemical reaction using hydrogen from the digester gas and oxygen**
- **Advantages:**
 - **Very low emissions**
 - **High energy recovery efficiency (w/ exhaust heat recovery)**
 - **Simple operation that is easily contracted out**
- **Disadvantages:**
 - **Gas reforming and pretreatment required**
 - **Capital Cost**

Fuel Cell Diagram

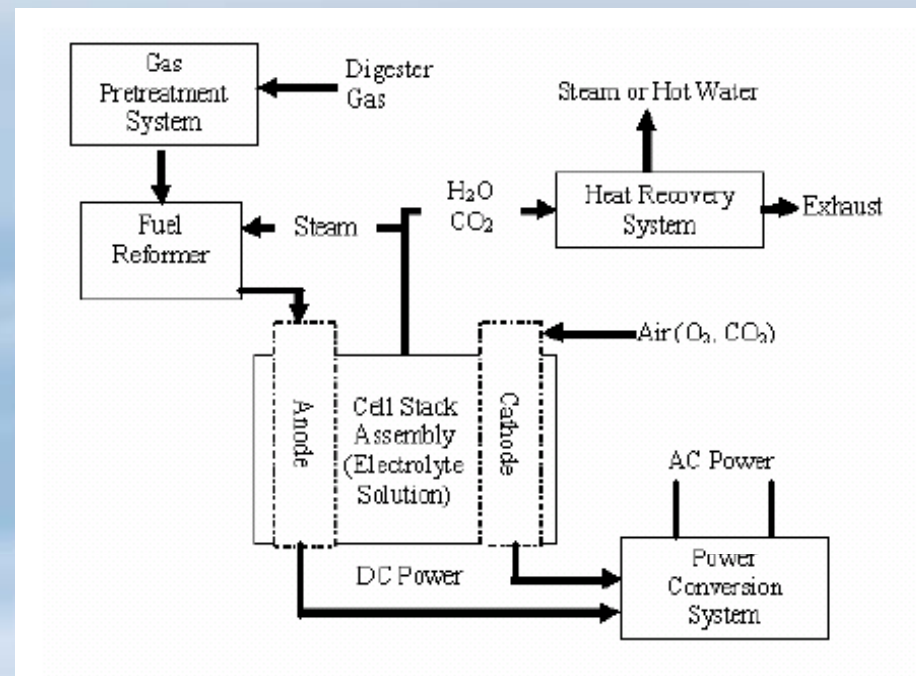

Fuel Cell Components

- **Gas pretreatment**
- **Fuel reformer**
- **Cell stack assembly**
- **Power Conversion System**
- **Heat Recovery System**

Fuel Cells Full-Scale

- **NYC WWTP**
 - **26th Ward, Red Hook, Oakwood Beach, Hunts Point**
 - **200, 400, and 600 kW units**
 - **Installed 2003**
 - **Total cost \$13 million**

250 kW Fuel Cell



Sludge-to-Syngas

- **Sewage sludge is converted to energy-rich gases that can be used to generate electricity**
- **Two-step process**
 1. **Pyrolysis step - the volatile fraction of the sludge is converted into a carbon-rich substance called “char”.**
 2. **Gasification step – the “char” is gasified in the presence of oxygen to syngas.**

Sludge-to-Oil

- **Sludge is converted to oil which can be used as an industrial fuel in boilers to produce steam or combusted in an engine to produce electricity.**
- **SlurryCarb™**

Sludge-to-Liquid

- **Supercritical water oxidation (SCWO) is a process that occurs in a water phase at temperatures above the supercritical point of water.**

Outline

- Keywords and Concepts
- Market Drivers
- The Status and Future of Biosolids Production, Reuse, and Disposal
- The Importance of Phosphorus
- Phosphorus Recovery Technologies
- Energy Importance, Independence and Environmental Impact
- Energy Recovery
- **Feasibility**

A Final Word - Feasibility

- **Technical - Does it work?**
- **Economic – Is it affordable?**
- **Social – Is it socially acceptable?**
 - **Values**
 - **Complexity**
 - **Chemical usage**
 - **Status in other countries.**

Contact Information



Robert C. Smith

Malcolm Pirnie
Project Engineer

(614) 430-2728
ROCSmith@pirnie.com
1900 Polaris Parkway
Suite 200
Columbus, OH 43240



Samuel S Jeyanayagam

Malcolm Pirnie
Senior Associate

(614) 430-2611
SJeyanayagam@PIRNIE.COM
1900 Polaris Parkway
Suite 200
Columbus, OH 43240 2020